

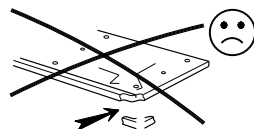

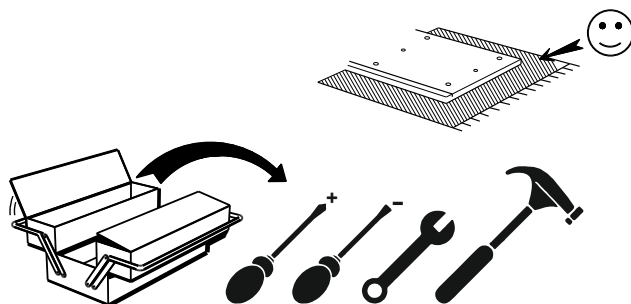

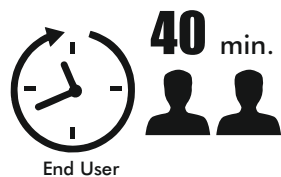

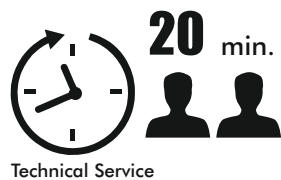

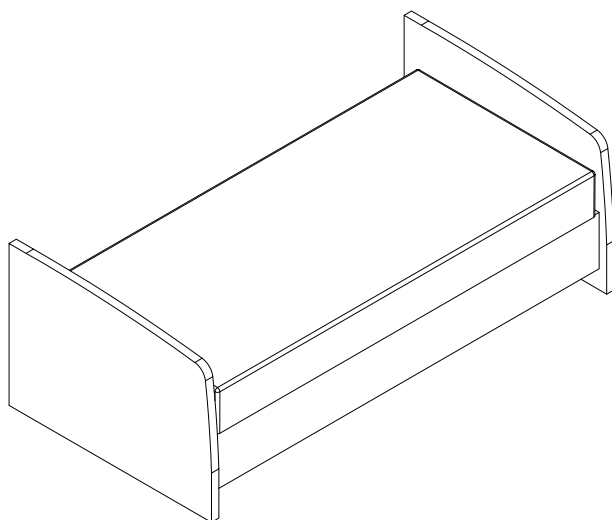

MULTIMO

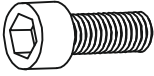
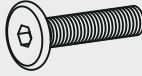
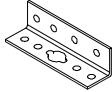
A 224 - SOFA

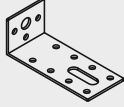

| Track Title | Piece | (inch) | | | (mm) | | | |
|-------------|-------|-----------|--------|-------|-------|-------|--------|------|
| | | Thickness | Length | Width | Piece | Thick | Height | Most |
| A | | 1,18 | 32,68 | 22,64 | 2 | 30 | 830 | 575 |
| B | | 0,71 | 62,60 | 9,84 | 1 | 18 | 1590 | 250 |
| C | | 0,71 | 62,60 | 10,63 | 1 | 18 | 1590 | 270 |
| D | | 0,71 | 61,18 | 28,82 | 1 | 18 | 1554 | 732 |

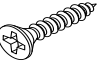
Accessories List

| | | | |
|--|---|--|--|
| IM - 01 (6x30) mm  8 / piece | CT - 02 (6x30) mm  6 / piece | KSB - 01  4 / piece | VTB - 01 (4,8x16) mm  24 / piece |
| AL - 01  4 | AL - 02  5 | DSE - 01 (40x90x32) mm  3 / piece | SN - 02 (M8)  8 / piece |
| VD - 03 (3,5x18) mm  12 / piece | PL - 01 (6x19x2) mm  8 / piece | | |

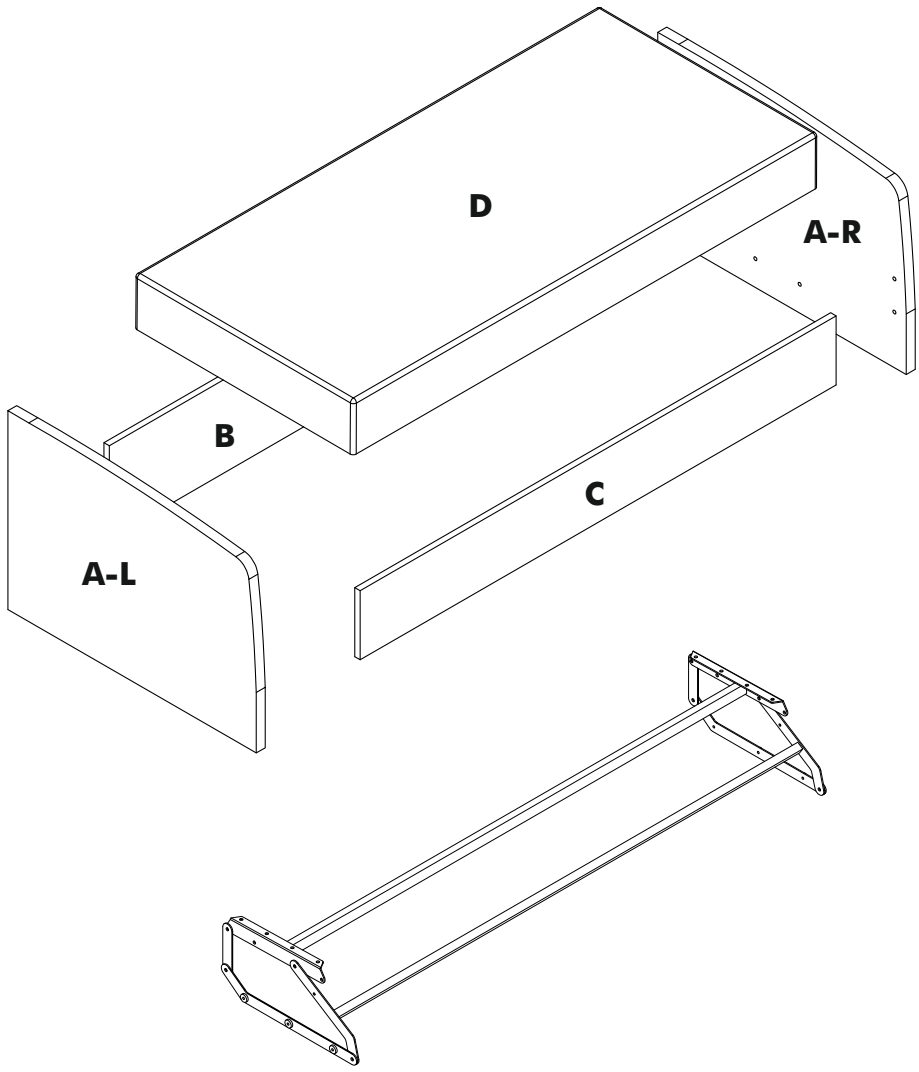

STEP 1

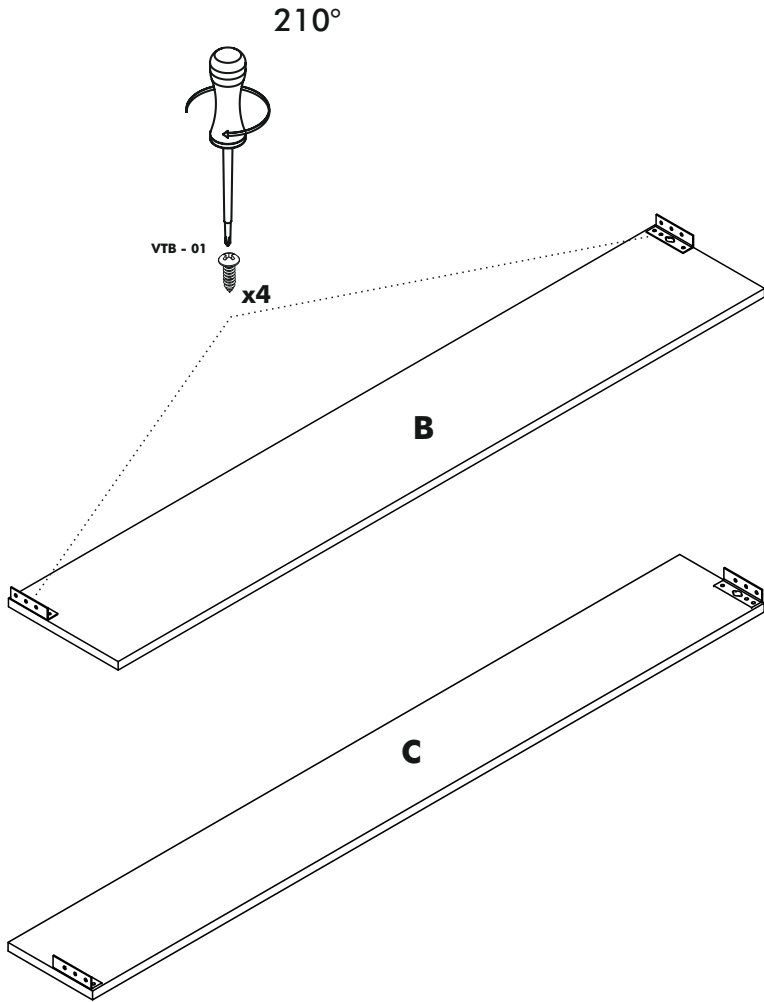

STEP 2

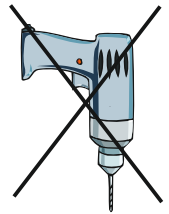
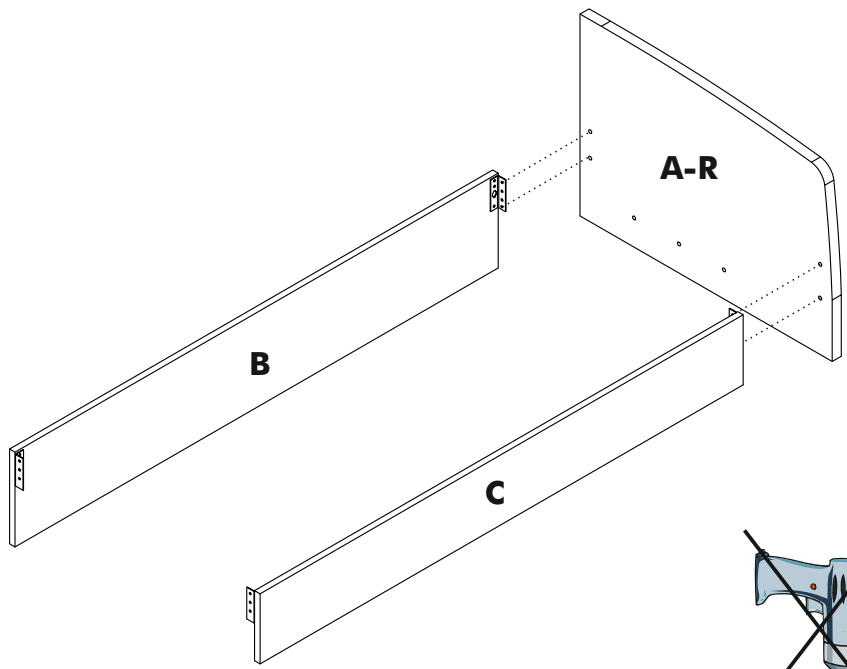

STEP 3

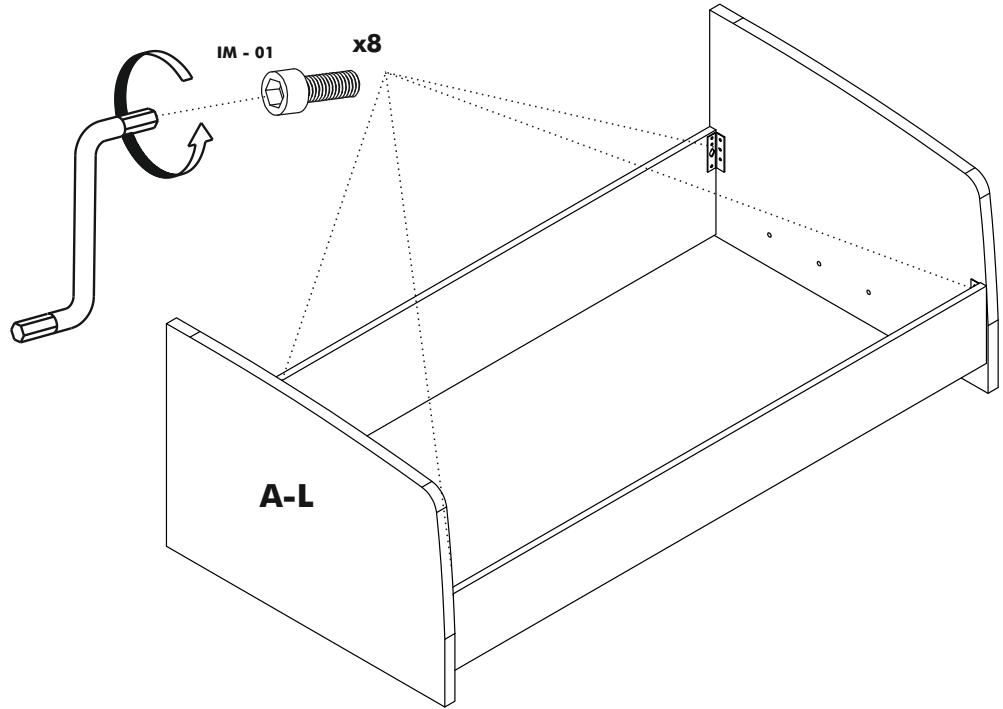

STEP 4

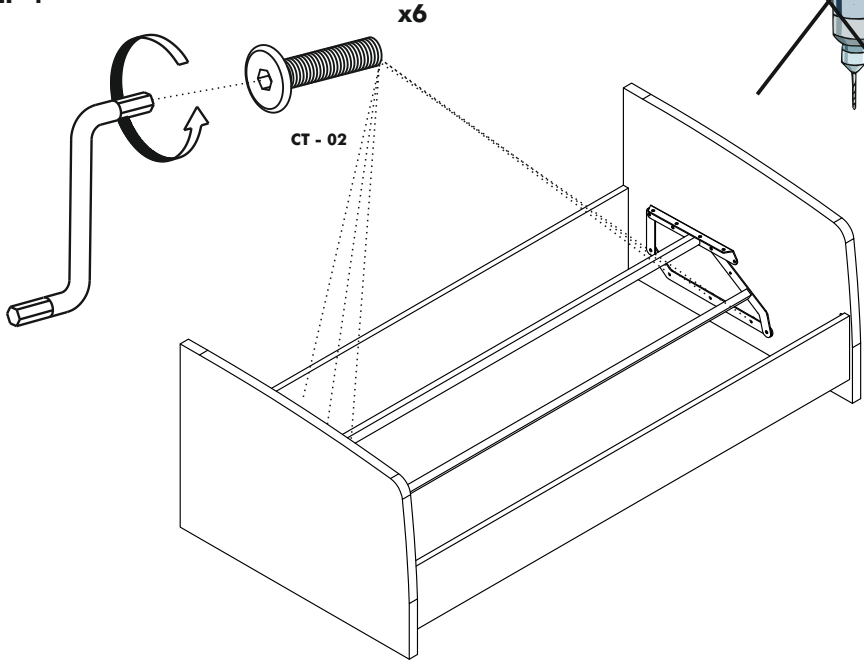

STEP 5

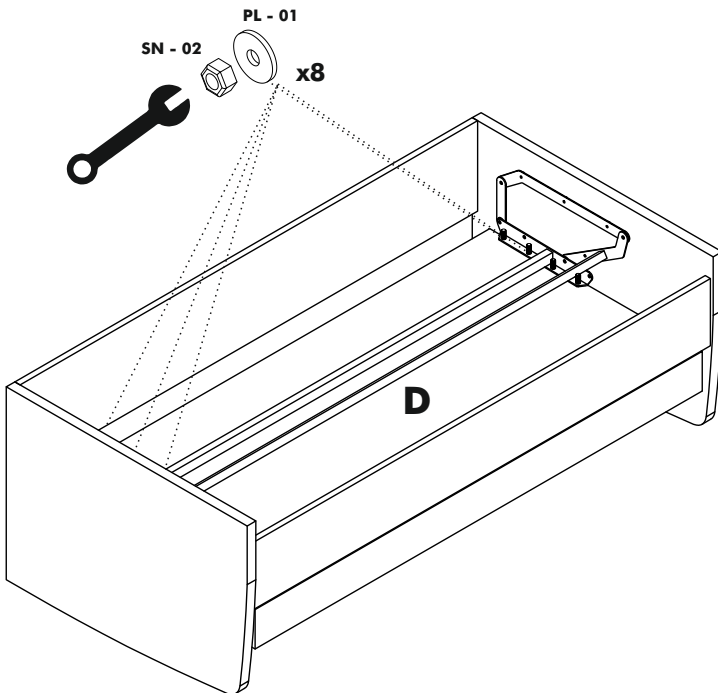

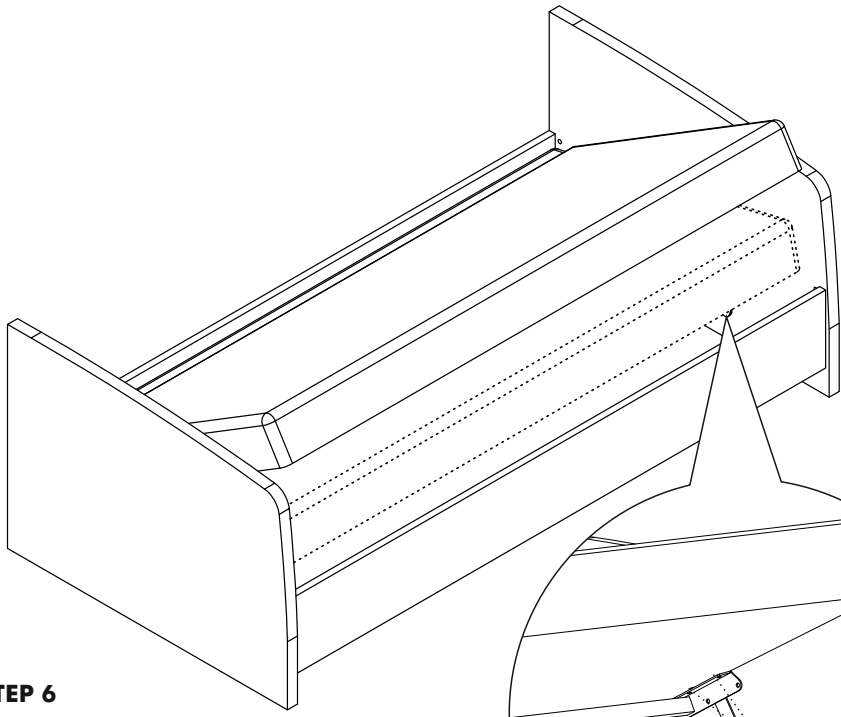

STEP 6

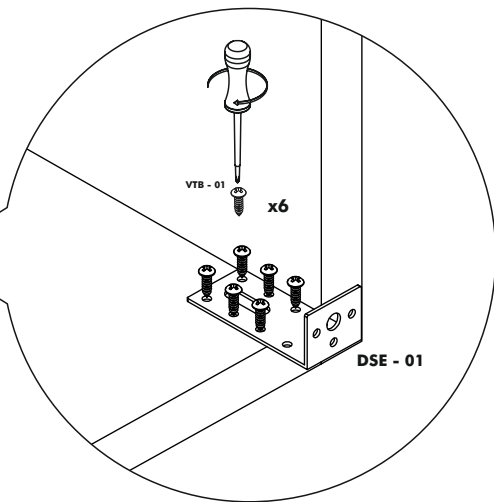
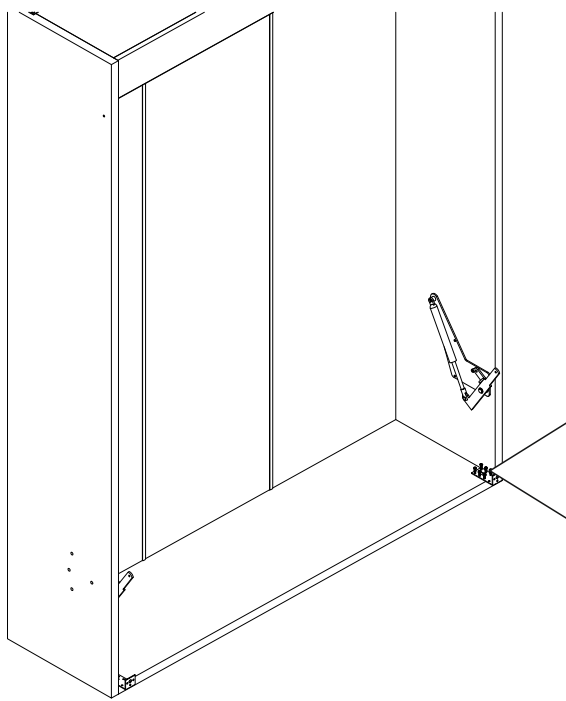
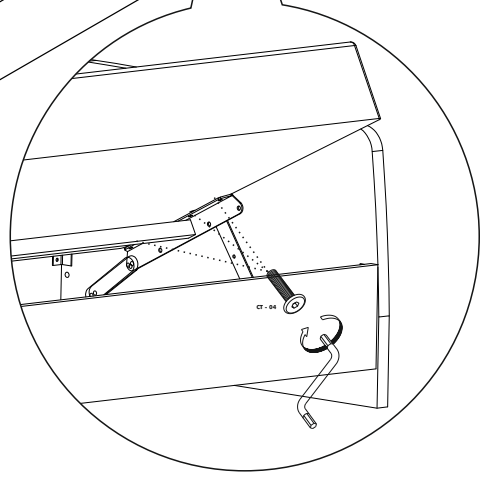

STEP 7

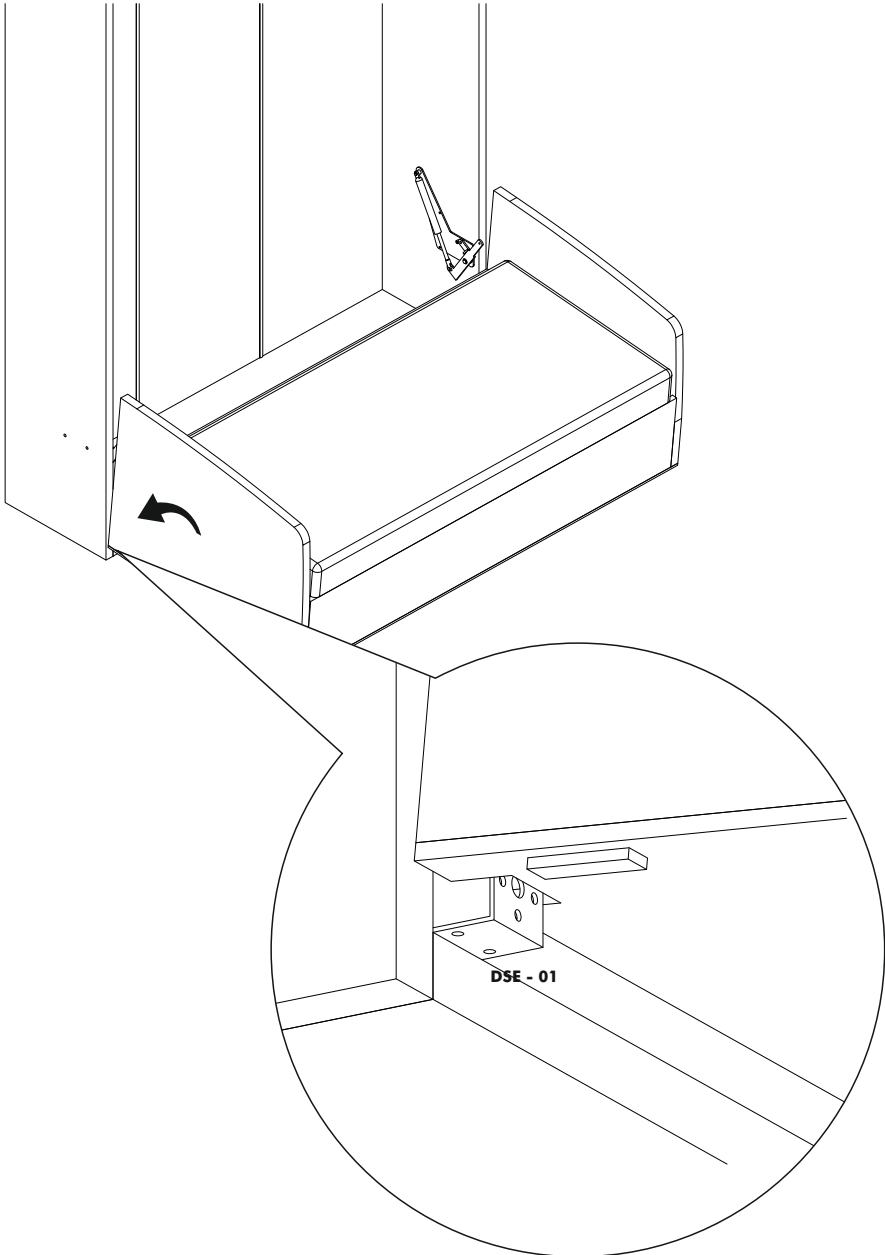

ATTENTION / HOW TO / READ ME / OWNER'S GUIDE

1. **Mounting of furniture must be to walls** made of brick, concrete or similar strong material. Wood or metal stud mounting is also acceptable. Paper-mache and sheet rock like walls are not suitable. Do not mount furniture to paper-mache or sheet rock like material as improper mounting may cause injury to person(s) and damage to property.
2. For safety and product longevity you must periodically inspect the mounting and mechanical connections for integrity and tightness. Confirm hardware remains properly affixed and connections snug.
3. Wall Bed mattress thickness may not exceed 8 inch. Take care to remove pillows and excess blankets before closing. Doing so keeps mechanism free of obstruction and unnecessary stress.
4. Do not lean or rest heavy objects on side or top of furniture. This may cause balance issues and compromise the integrity of your mounting connections.
5. Please use the furniture's beds, desks and shelving as intended. Not designed to be sat, stood, leaned, jumped (etc) on. Improper use may cause personal injury and damage to property.
6. With seasonal humidity change you must inspect interior and exterior of furniture.
7. Single, Twin, Twin XL beds accommodate the weight of one person. Improperly sleeping more than one person risks injury to person and damage to property.
8. Before any un-mounting or disassembly please contact Multimo for technical support and instruction. Failure to properly detach risks injury to person and damage to property.
9. For Bunk Beds:
 - a. Always use provided ladder when accessing top bunk.
 - b. Be slow, careful and aware of surroundings when opening top bunk.
 - c. Do not horseplay. Beds are to be slept on only.
 - d. Some have legs that fully extend when open- be aware of where the leg is and will be.



MULTiMO

www.multimobeds.com